



Product Description

Flintec load pins are designed to meet the most stringent accuracy and environmental conditions.

In addition to a standard range of load pins, Flintec is able to design and manufacture load pins to suit specific customer applications. Typical applications include crane and hoist load/condition monitoring as well as numerous applications in the fields of safety, industrial measurement, vehicles and aerospace industries.

Load pins can be supplied with alloy or stainless steel construction and in a range of capacities. Designed to measure force in a single axis, the internal strain gage sensing circuit is employed to ensure highest accuracy and optimum reliability.

In addition, Flintec load pins are (can be) supplied with the calibration technique (in mV/V/Ohm) which eliminates time consuming calibration in multi-pin applications.

Other designs of load pin with integrated electronic amplifiers are also available.

Specifications

Maximum capacity	(E _{max})	t	1 / 2 / 2.5 / 5	10
Accuracy		%*RO	≤ ± 0.5	
Repeatability		%*RO	≤ ± 0.1	
Temperature effect on minimum dead load output	(TC ₀)	%*RO/10°C	≤ ± 0.25	
Temperature effect on sensitivity	(TC _{RO})	%*RO/10°C	≤ ± 0.10	
Rated Output	(RO)	mV/V	1.5 ± 0.1%	
Zero balance		%*RO	≤ ± 2	
Excitation voltage		V	5...10	
Input resistance	(R _{LC})	Ω	375 ± 10	
Output resistance	(R _{out})	Ω	375 ± 10	
Insulation resistance (100 V DC)		MΩ	≥ 5 000	
Safe load limit	(E _{lim})	%*E _{max}	150	
Operating temperature range		°C	-30...+70	
Load cell material			stainless steel 17-4 PH (1.4548)	
Sealing			potted	
Protection according DIN 40.050			IP67	

Dimensions (in mm)

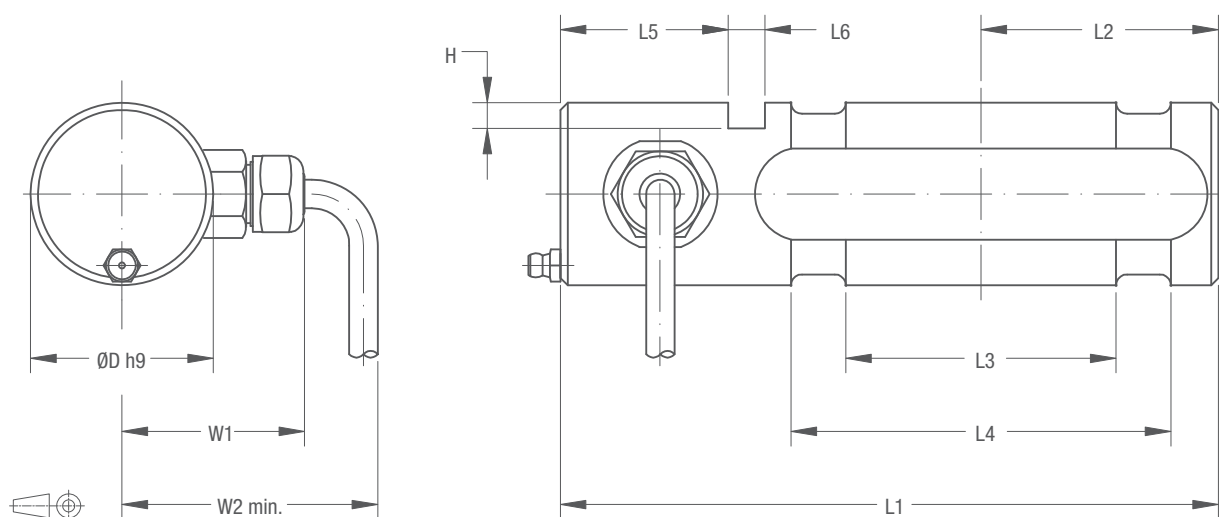

Type	D	W1	W2	L1	L2	L3	L4	L5	L6	H
LP1-1/2 t	25	25	35	90	32.5	37	52	23	5	3.5
LP1-2.5/5 t	31.75	29	39	120	45.5	50.8	72.75	26	5	5
LP1-10 t	31.75	29	39	120	45.5	50.8	66.8	26	5	5

Wiring

- The load pin is provided with a shielded, 4 conductor cable (AWG 24). Cable jacket polyurethane.
- Cable length: 3 m.
- Cable diameter: 5 mm.
- The shield is floating
(On requested the shield can be connected to the load cell body).

