



Its small size is remarkable; the knurled part “bites” into your structure



Product Description

The TULIP Transducer is designed to be implanted into the heart of the structure to provide dependable strain sensing. The Press-Fit construction allows easy installation.

This load sensor gives the machine, device or structure an accurate load sensing capability by simply drilling a hole.

The economic solution for:

- **Industrial weighing**
- **Level control systems**
- **Machine control systems**

The idea of developing a sensor capable of being integrated into a mechanical structure has resulted in the TULIP Transducer.

Its unique shape (sensing strain in 2 axes) combined with proven strain gauge technology solves a wide range of actual application problems.

Installation normally requires only machining a suitable hole in the structural part, and insertion of the sensor.

The sensor’s accuracy combined with its stainless steel and hermetically sealed housing guarantees success in the worst hostile environments.

The sensor has unchallenged application versatility; virtually any machine, device or structure can use this sensor as a cost effective, accurate solution to your sensing needs. Only the designer’s ingenuity limits the application of this concept.

Compared to similar products in the market like Bolt-On types, the TULIP has specific advantages:

- Because of its unique ability to sense strain in 2 axes, zero shift due to thermal effects are greatly reduced.
- The TULIP is hermetically sealed.
- The press-fit construction allows better long term stability.
- The press-fit construction allows installation in the neutral axis of the structure.

Applications

- Silo weighing systems
- Tank weighing systems
- Agricultural equipment
- Lift trucks
- Structural load measuring
- Crane weighing
- Crane overload protection sensing
- Rolling mill sensing
- Machine tool wear sensing
- One-off special load cells
- ... and your load sensing application

Key Features

- Capacity ranging from hundreds of kg to thousands of t, all with the same sensor; depending on your structure
- Simple press fit mounting
- Easily installable in existing structures
- Stainless steel construction
- Hermetically sealed
- Minimal temperature effect
- Measures
 - Compression
 - Tension
 - Shear
 - Bending
 - Torsion
- Easy adaptable in OEM products

Principle of operation

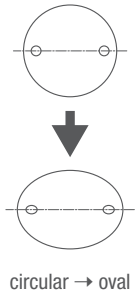

The TULIP Transducer operates on the following principle:

When a mechanical structure is subjected to an external load, the structure changes shape to resist the force. Although the change is microscopic it can be monitored by the sensor. If a small hole is made in the structure, the hole will deform as the structure deforms in direct proportion to the load.

By inserting the sensor tightly into the hole, this deformation can be measured extremely accurately (circular → oval = strain). Thus, the sensor effectively turns the entire structure into a load or force transducer.

The figure shows the TULIP Transducer with its 3 principal axes.

The sensor has two principle axes of strain measurement, disposed 90° to each other, marked X-axis and Y-axis.

These sensitive axes are aligned in the middle of the knurl. The sensor is not sensitive in the Z-axis.

The X-axis is the alignment-axis for the sensor. The alignment marks show this axis on the front and back diaphragms of the sensor.

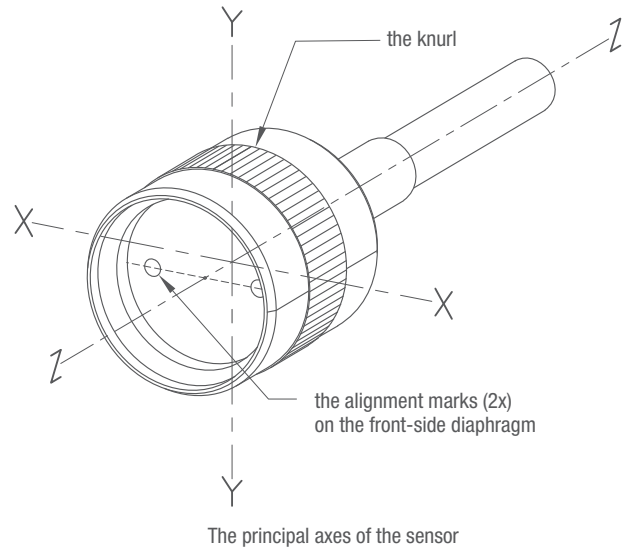

The alignment

Care must be taken to properly align the sensor in the strain field in order to obtain correct polarity of the output signal. The alignment mark on the sensor must be aligned with the principal axis of strain.

The alignment marks on the sensor indicate the X-axis. These marks have to be aligned with the principal axis of the strain in the mechanical structure.

Depending on the mechanical structure and the applied load, various sensing methods may be employed. The alignment of the sensor depends on these sensing methods.

The main sensing methods are: compression, tension and shear. But also bending and torsion can be measured.

Sensing methods are indicated below.

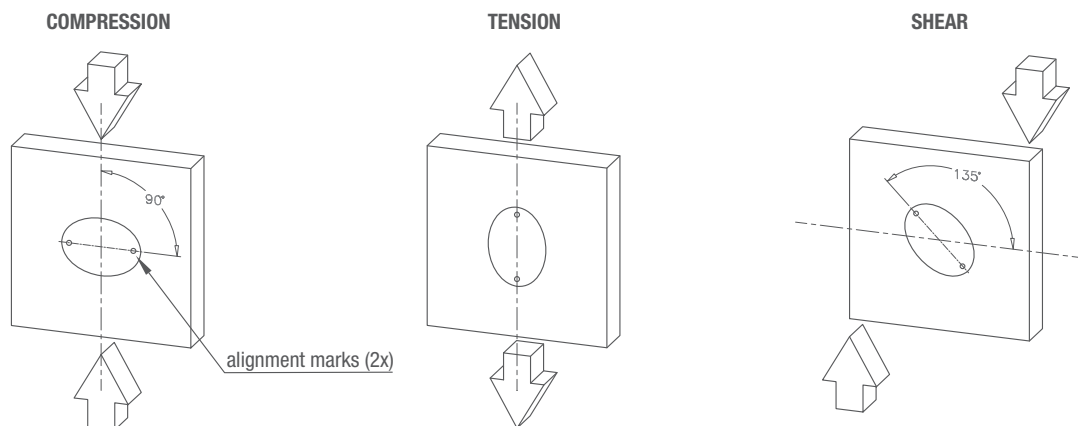

The main sensing methods

Specifications

Type		TULIP
Excitation voltage	V	5...12
Input resistance	(R_{LC}) Ω	700 ± 20
Output resistance	(R_{out}) Ω	700 ± 20
Minimum stress level:		
For steel in compression/tension applications	N/mm ²	≥ 20
For steel in shear applications	N/mm ²	≥ 10
Output Voltage at this minimum stress level (=FS):		
For steel in compression/tension applications	mV/V	≥ 0.2
For steel in shear applications	mV/V	≥ 0.2
Zero Balance	mV/V	$\leq \pm 0.25$
Non-Repeatability	%*FS	$\leq \pm 0.1$
Temperature effect on minimum dead load output	mV/V/°C	$\leq \pm 0.0003$
Temperature effect on sensitivity	%*FS/°C	$\leq \pm 0.03$
Operating Temperature Range	°C	-40...+80
Storage Temperature Range	°C	-50...+90
Insulation Resistance	M Ω	≥ 5000
Sealing (DIN 40.050)	IP	68
Cable length:		
standard	m	0.5
optionally	m	10

A total system accuracy can be achieved between 0.5% and 5%, depending on the mechanical structure and the environmental conditions.

Dimensions (in mm)

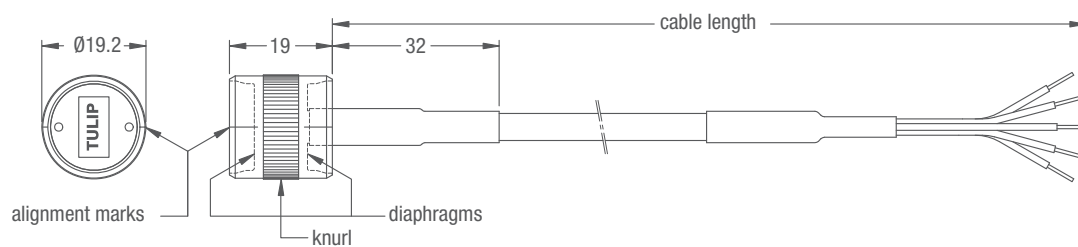

The press-fit construction requires a precision hole.

This insertion-hole should be machined properly; dimension of the hole must be $\varnothing 19.05 \pm 0.05$ mm.

Accessories

- The TULIP Toolkit is available to drill the hole and to press the TULIP inside (see next page).
- A special junction box Type KP1 is available including mounting and protection plate to be installed in the direct vicinity of the TULIP sensor.
A modulus resistor is installed for additional TC span compensation.

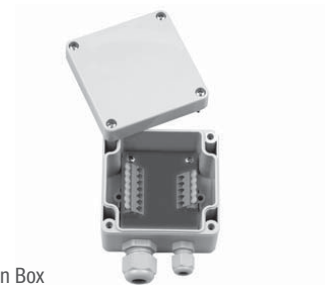

The KP1 Junction Box

Wiring

The TULIP Transducer is configured with a full bridge circuit (Wheatstone bridge). This offers low non-linearity, hysteresis and non-repeatability. The load cell is provided with a shielded, 4 conductor cable (AWG 24). Cable jacket polyurethane. Cable diameter 5 mm. The shield is floating.

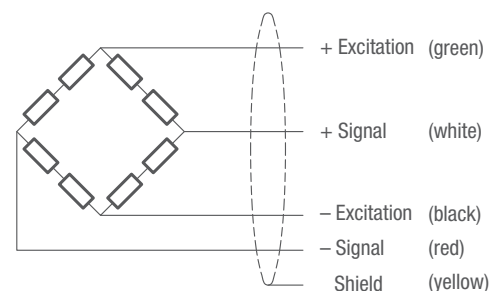

Installation

For field installation, the TULIP Toolkit is available.

This toolkit should be used to drill the hole properly. It avoids problems of a lack of perpendicularity to the load axis, improper hole tolerances and ovality.

The same tool can also press the sensor into place.

Notes

The location of the TULIP Transducer is very important. Ideally, the sensor should be applied to a structural member at a point which is characterized by a uniform strain pattern.

Position the sensor as close as possible to the neutral axis of the force you wish to ignore. As an example: in the drawing on this page the object is to measure the compression in the bar. Install the sensor in the centerline of the bar to avoid bending influences. Align the sensor properly.

The diaphragms are very sensitive. Take care not to damage the diaphragms during installation.

After installation, protect the sensor, hole and beam from corrosion by using primer, paint or other anti-corrosion system.

After installation the sensor's output can be calibrated to meet your systems needs. The maximum load depends on your structure. Applications can have full scale loads ranging from hundreds of kg to thousands of t.

Attention: A zero shift will usually occur upon installation. The magnitude of the shift depends on the ovality of the hole and the installation procedure used. This zero shift can be compensated in the electronic instrumentation attached.

For much more details the TULIP Manual is available.

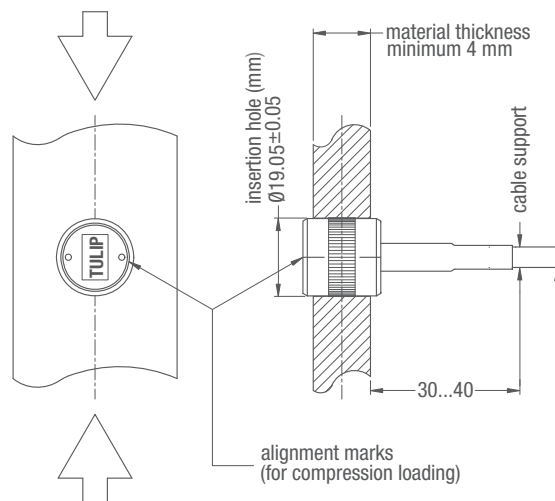
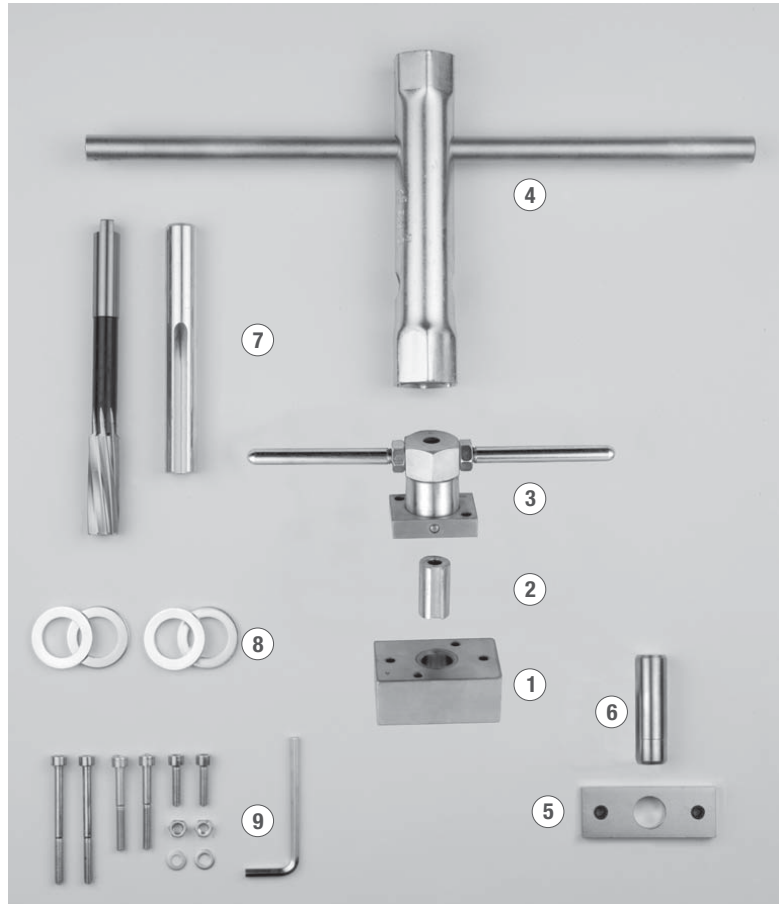

The structural arrangement